



HB/HBA

Wall fan with variable pitch blades
Mural de pala variable



MANUFACTURING FEATURES

- Wall axial fan with circular reinforced frame made of sheet steel.
- Motor-impeller modular assembly for complete versatility.
- Protected against corrosion by powder coating of polyester resin.
- Standard asynchronous squirrel-cage motor with IP-55 protection and Class F insulation. Manufactured with standard voltages: 230V 50Hz in single phase motors, 230/400V 50Hz in three phase motors up to 4kW and 400/690V 50Hz for higher powers.
- HB: polyamide impeller with variable pitch angle reinforced with fibreglass
- HBA: cast aluminium impeller with variable pitch angle.

APPLICATIONS

- Designed for wall or duct installation, they are suitable for:
- Air renewal in buildings and industries.
 - Maximum continuous working temperature: single phase 50°C, three phase 60°C.

UNDER REQUEST

- B form impeller (air flow from impeller to motor).
- 100% reversible impeller.
- Hot-dipped galvanised or stainless steel housing.

CARACTERÍSTICAS CONSTRUCTIVAS

- Ventilador helicoidal de marco redondo reforzado con nervio intermedio en chapa de acero laminado.
- Montaje modular del conjunto motor hélice que permite una total versatilidad en caso de cualquier cambio.
- Protegidos contra la corrosión mediante recubrimiento en polvo de resina de poliéster.
- Motor asíncrono normalizado de jaula de ardilla con protección IP-55 y aislamiento clase F. Voltajes estándar 230V 60Hz para motores monofásicos, 230/400-460V 60Hz para motores trifásicos hasta 4kW y 400-460/690V 60Hz para potencias superiores.
- HB: hélice de poliamida reforzada con fibra de vidrio de ángulo variable en origen.
- HBA: hélice en fundición de aluminio de ángulo variable en origen.

APLICACIONES

- Diseñados para montaje en pared o en conducto, son indicados para:
- Renovación de aire en todo tipo de edificios e industrias.
 - Temperatura máxima de trabajo en continuo: monofásicos 50°C, trifásicos 60°C.

BAJO DEMANDA

- Hélice impelente (sentido de aire hélice-motor).
- Hélice reversible 100%.
- Envoltorio en chapa galvanizada en caliente o acero inoxidable.

ACCESSORIES / accesorios



INT

Interruptor de corte
Safety switch



RPO

Rejilla de protección impulsión
Outlet Protection Guard



SFC

Variador de velocidad frecuencial
Frequency speed controller



MC HB

Marco soporte cuadrado para HB
Square mounting frame for HB



PCP

Persiana sobrepresión en plástico
Plastic gravity shutter



PC2

Persiana sobrepresión en aluminio
Aluminium overpressure damper



RP1

Rejilla de protección aspiración
Inlet protection guard

SINGLE PHASE RANGE / serie monofásica

2 POLE / 2 polos

Model	Angle	Min. Rated power kW	Max. Rated power kW	Max. Airflow m ³ /h	Sound dB (A) **	Weight Kg	Connection diagram
HB / HBA 35 M2 (A0:6)	25° - 40°	0,55	1,10	6.810	60	9,40	1



4 POLE / 4 polos

Model	Angle	Min. Rated power kW	Max. Rated power kW	Max. Airflow m ³ /h	Sound dB (A) **	Weight Kg *	Connection diagram
HB / HBA 35 M4 (A0:6)	35° - 40°	0,12	0,12	3.440	46	9,4	1
HB / HBA 40 M4 (A0:6)	35° - 40°	0,18	0,25	4.670	51	10,9	1
HB / HBA 45 M4 (A0:6)	35° - 40°	0,25	0,25	6.360	52	13,1	1
HB / HBA 45 M4 (A5:6)	25° - 45°	0,18	0,55	6.760	51	15,4	1
HB / HBA 50 M4 (A0:6)	35° - 40°	0,37	0,37	8.140	53	17,3	1
HB / HBA 50 M4 (A5:6)	25° - 45°	0,25	0,75	9.420	54	19,7	1
HB / HBA 56 M4 (A2:6)	20° - 45°	0,37	0,75	13.910	60	20,8	1
HB / HBA 56 M4 (A2:9)	20° - 45°	0,37	0,75	14.710	60	21,3	1
HB / HBA 56 M4 (A5:6)	20° - 45°	0,37	0,75	14.640	70	22,5	1
HB / HBA 63 M4 (A2:6)	20° - 30°	0,37	0,75	13.810	60	24,6	1
HB / HBA 63 M4 (A2:9)	20° - 27,5°	0,37	0,75	12.510	62	25,2	1
HB / HBA 63 M4 (A5:6)	20° - 25°	0,37	0,75	12.020	63	26,5	1
HB / HBA 71 M4 (A2:6)	20° - 25°	0,75	0,75	15.510	64	28,6	1
HB / HBA 71 M4 (A2:9)	20° - 20°	0,75	0,75	12.080	68	29,2	1
HB / HBA 71 M4 (A5:6)	20° - 20°	0,75	0,75	13.640	66	30,6	1

6 POLE / 6 polos

Model	Angle	Min. Rated power kW	Max. Rated power kW	Max. Airflow m ³ /h	Sound dB (A) **	Weight Kg *	Connection diagram
HB / HBA 56 M6 (A2:6)	20° - 45°	0,12	0,25	9.000	51	20,8	1
HB / HBA 56 M6 (A2:9)	20° - 45°	0,12	0,37	9.520	51	21,3	1
HB / HBA 56 M6 (A5:6)	20° - 45°	0,12	0,25	9.760	67	22,5	1
HB / HBA 63 M6 (A2:6)	20° - 45°	0,37	0,37	13.010	53	24,6	1
HB / HBA 63 M6 (A2:9)	20° - 45°	0,37	0,25	14.110	53	25,2	1
HB / HBA 63 M6 (A5:6)	20° - 45°	0,37	0,37	13.570	71	26,5	1
HB / HBA 71 M6 (A2:6)	20° - 45°	0,37	0,37	18.110	56	28,6	1
HB / HBA 71 M6 (A2:9)	20° - 45°	0,37	0,37	19.610	58	29,2	1
HB / HBA 71 M6 (A5:6)	20° - 45°	0,37	0,37	18.350	76	30,6	1

THREE PHASE RANGE / serie trifásica

2 POLE / 2 polos

Model	Angle	Min. Rated power kW	Max. Rated power kW	Max. Airflow m ³ /h	Sound dB (A) **	Weight Kg *	Connection diagram
HB / HBA 35 T2 (A0:6)	25° - 40°	0,55	1,1	6.810	60	9,4	2
HB / HBA 40 T2 (A0:6)	25° - 40°	0,75	1,1	9.270	62	10,9	2
HB / HBA 45 T2 (A0:6)	25° - 35°	1,5	2,2	11.800	68	13,1	2

4 POLE / 4 polos

Model	Angle	Min. Rated power kW	Max. Rated power kW	Max. Airflow m ³ /h	Sound dB (A) **	Weight Kg *	Connection diagram
HB / HBA 35 T4 (A0:6)	35° - 40°	0,12	0,12	3.440	46	9,4	2
HB / HBA 40 T4 (A0:6)	35° - 40°	0,18	0,18	4.670	51	10,9	2
HB / HBA 45 T4 (A0:6)	35° - 40°	0,25	0,25	6.360	52	13,1	2
HB / HBA 45 T4 (A5:6)	25° - 45°	0,18	0,55	6.760	51	15,4	2
HB / HBA 50 T4 (A0:6)	35° - 40°	0,37	0,37	8.140	53	17,3	2
HB / HBA 50 T4 (A5:6)	25° - 45°	0,25	0,75	9.420	54	19,7	2
HB / HBA 56 T4 (A2:6)	20° - 45°	0,37	2,2	13.910	60	20,8	2
HB / HBA 56 T4 (A2:9)	20° - 45°	0,37	2,2	14.710	60	21,3	2
HB / HBA 56 T4 (A5:6)	20° - 45°	0,37	2,2	14.640	70	22,5	2
HB / HBA 63 T4 (A2:6)	20° - 45°	0,37	3	20.110	62	24,6	2
HB / HBA 63 T4 (A2:9)	20° - 45°	0,37	3	21.810	63	25,2	2
HB / HBA 63 T4 (A5:6)	20° - 45°	0,37	3	20.350	74	26,5	2
HB / HBA 71 T4 (A2:6)	20° - 45°	0,75	4	27.910	65	28,6	2
HB / HBA 71 T4 (A2:9)	20° - 45°	0,75	4	30.310	68	29,2	2
HB / HBA 71 T4 (A5:6)	20° - 45°	0,75	4	27.520	79	30,6	2
HB / HBA 80 T4 (A2:6)	20° - 45°	1,1	9,2	39.010	67	34	2
HB / HBA 80 T4 (A2:9)	20° - 45°	1,1	9,2	41.810	72	34,6	2
HB / HBA 80 T4 (A5:6)	20° - 40°	1,1	4	34.470	71	36,3	2
HB / HBA 90 T4 (A6:3)	20° - 42°	3	15	50.950	75	55,3	2
HB / HBA 90 T4 (A6:6)	20° - 42°	3	15	58.310	76	60,7	2
HB / HBA 100 T4 (A6:3)	20° - 42°	5,5	22	69.340	76	67,6	2



Model	Angle	Min. Rated power kW	Max. Rated power kW	Max. Airflow m ³ /h	Sound dB (A) **	Weight Kg *	Connection diagram
HB / HBA 100 T4 (A6:6)	20° - 42°	5,5	22	81.210	80	73,7	2
HB / HBA 112 T4 (A6:3)	20° - 42°	5,5	37	92.050	78	76,5	2
HB / HBA 112 T4 (A6:6)	20° - 42°	5,5	37	109.010	83	83,2	2
HB / HBA 125 T4 (A7:4)	20° - 42°	7,5	45	132.010	85	91,2	2
HB / HBA 125 T4 (A7:8)	20° - 42°	11	45	151.010	89	100,3	2

6 POLE / 6 polos

Model	Angle	Min. Rated power kW	Max. Rated power kW	Max. Airflow m ³ /h	Sound dB (A) **	Weight Kg *	Connection diagram
HB / HBA 35 T6 (A0:6)	35° - 40°	0,12	0,12	2.230	37	9,4	2
HB / HBA 40 T6 (A0:6)	35° - 40°	0,12	0,12	3.030	42	10,9	2
HB / HBA 45 T6 (A0:6)	35° - 40°	0,12	0,12	4.120	42	13,1	2
HB / HBA 45 T6 (A5:6)	25° - 45°	0,12	0,12	4.380	42	15,4	2
HB / HBA 50 T6 (A0:6)	35° - 40°	0,12	0,12	5.270	44	17,3	2
HB / HBA 50 T6 (A5:6)	25° - 45°	0,12	0,18	6.100	45	19,7	2
HB / HBA 56 T6 (A2:6)	20° - 45°	0,12	0,55	9.000	51	20,8	2
HB / HBA 56 T6 (A2:9)	20° - 45°	0,12	0,55	9.520	51	21,3	2
HB / HBA 56 T6 (A5:6)	20° - 45°	0,12	0,55	9.760	67	22,5	2
HB / HBA 63 T6 (A2:6)	20° - 45°	0,37	0,75	13.010	53	24,6	2
HB / HBA 63 T6 (A2:9)	20° - 45°	0,37	0,75	14.110	53	25,2	2
HB / HBA 63 T6 (A5:6)	20° - 45°	0,37	0,75	13.570	71	26,5	2
HB / HBA 71 T6 (A2:6)	20° - 45°	0,37	1,1	18.110	56	28,6	2
HB / HBA 71 T6 (A2:9)	20° - 45°	0,37	1,1	19.610	58	29,2	2
HB / HBA 71 T6 (A5:6)	20° - 45°	0,37	1,1	18.350	76	30,6	2
HB / HBA 80 T6 (A2:6)	20° - 45°	0,37	2,2	25.310	57	34	2
HB / HBA 80 T6 (A2:9)	20° - 45°	0,37	2,2	27.110	63	34,6	2
HB / HBA 80 T6 (A5:6)	20° - 45°	0,37	2,2	25.190	72	36,3	2
HB / HBA 90 T6 (A6:3)	20° - 42°	0,75	4	33.010	65	55,3	2
HB / HBA 90 T6 (A6:6)	20° - 42°	0,75	4	37.810	66	60,7	2
HB / HBA 100 T6 (A6:3)	20° - 42°	1,1	7,5	44.970	66	67,6	2
HB / HBA 100 T6 (A6:6)	20° - 42°	1,1	7,5	52.610	70	73,7	2
HB / HBA 112 T6 (A6:3)	20° - 42°	1,5	11	59.660	69	76,5	2
HB / HBA 112 T6 (A6:6)	20° - 42°	1,5	11	70.510	73	83,2	2

THREE PHASE 2 SPEEDS RANGE / serie trifásica 2 velocidades
4/8 POLE / 4/8 polos

Model	Angle	Min. Rated power kW	Max. Rated power kW	Max. Airflow m ³ /h	Sound dB (A) **	Weight Kg *	Connection diagram
HB / HBA 35 T4/T8 (A0:6)	35° - 40°	0,25	0,25	3.440	46	9,4	3
HB / HBA 40 T4/T8 (A0:6)	35° - 40°	0,25	0,25	4.670	51	10,9	3
HB / HBA 45 T4/T8 (A0:6)	35° - 40°	0,25	0,25	6.360	52	13,1	3
HB / HBA 45 T4/T8 (A5:6)	25° - 45°	0,25	0,55	6.760	51	15,4	3
HB / HBA 50 T4/T8 (A0:6)	35° - 40°	0,33	0,33	8.140	53	17,3	3
HB / HBA 50 T4/T8 (A5:6)	25° - 45°	0,25	0,75	9.420	54	19,7	3
HB / HBA 56 T4/T8 (A2:6)	20° - 45°	0,33	2,2	13.910	60	20,8	3
HB / HBA 56 T4/T8 (A2:9)	20° - 45°	0,33	2,2	14.710	60	21,3	3
HB / HBA 56 T4/T8 (A5:6)	20° - 45°	0,33	2,2	14.640	70	22,5	3
HB / HBA 63 T4/T8 (A2:6)	20° - 45°	0,33	3	20.110	62	24,6	3
HB / HBA 63 T4/T8 (A2:9)	20° - 45°	0,33	3	21.810	63	25,2	3
HB / HBA 63 T4/T8 (A5:6)	20° - 45°	0,33	3	20.350	74	26,5	3
HB / HBA 71 T4/T8 (A2:6)	20° - 45°	0,75	4	27.910	65	28,6	3
HB / HBA 71 T4/T8 (A2:9)	20° - 45°	0,75	4	30.310	68	29,2	3
HB / HBA 71 T4/T8 (A5:6)	20° - 45°	0,75	4	27.520	79	30,6	3
HB / HBA 80 T4/T8 (A2:6)	20° - 45°	1,1	7,5	39.010	67	34	3
HB / HBA 80 T4/T8 (A2:9)	20° - 45°	1,1	7,5	41.810	72	34,6	3
HB / HBA 80 T4/T8 (A5:6)	20° - 45°	1,1	4	37.780	76	36,3	3
HB / HBA 90 T4/T8 (A6:3)	20° - 42°	3	15	50.950	75	55,3	3
HB / HBA 90 T4/T8 (A6:6)	20° - 42°	3	15	58.310	76	60,7	3
HB / HBA 100 T4/T8 (A6:3)	20° - 42°	5,5	20	69.340	76	67,6	3
HB / HBA 100 T4/T8 (A6:6)	20° - 42°	5,5	20	81.210	80	73,7	3
HB / HBA 112 T4/T8 (A6:3)	20° - 42°	5,5	37	92.050	78	76,5	3
HB / HBA 112 T4/T8 (A6:6)	20° - 42°	5,5	37	109.010	83	83,2	3
HB / HBA 125 T4/T8 (A7:4)	20° - 42°	7,5	44	132.010	85	91,2	3
HB / HBA 125 T4/T8 (A7:8)	20° - 42°	11	44	151.010	89	100,3	3

* The motor is not included in fan weight / el peso del ventilador no incluye el motor

** Total sound pressure level at the point of maximum flow measured in dB(A) in the suction measured in free field at a distance of 6m from the source / Nivel de presión sonora total en el punto de caudal máximo medido en dB(A) en la aspiración, medido en campo libre a una distancia de 6m de la fuente.



DIMENSIONS / dimensiones

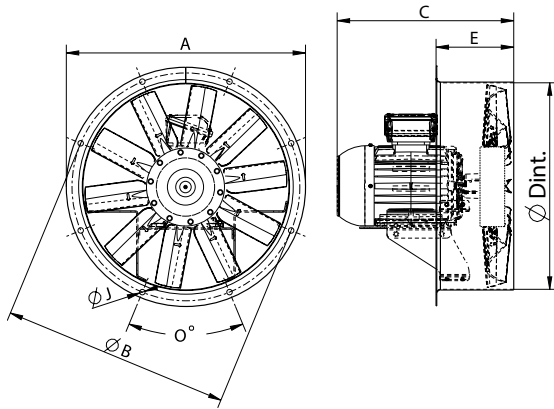

MODEL	ØA	ØB	ØD	E	ØI	O
HB / HBA 35	434	395	365	150	10	8x45°
HB / HBA 40	472	450	403	150	10	8x45°
HB / HBA 45	525	500	452	170	12	8x45°
HB / HBA 50	600	560	504	170	12	12x30°
HB / HBA 56	646	620	559	175	12	12x30°
HB / HBA 63	725	690	633	185	12	12x30°
HB / HBA 71	802	770	715	190	12	16x22,5°
HB / HBA 80	892	860	801	220	12	16x22,5°
HB / HBA 90	1000	970	903,5	340	12	16x22,5°
HB / HBA 100	1115	1070	1013	340	12	16x22,5°
HB / HBA 112	1234	1190	1132	340	12	16x22,5°
HB / HBA 125	1365	1320	1263	340	15	20x18°

C' max. Aprox. (Consult motor size table / Consultar tabla tamaño constructivo motor)															
model	63	71	80	90S	90L	100L	112M	132S	132M	160M	160L	180M	180L	200	225
HB / HBA 35	303	306	335	-	-	-	-	-	-	-	-	-	-	-	-
HB / HBA 40	-	301	335	352	377	-	-	-	-	-	-	-	-	-	-
HB / HBA 45	328	328	347	362	387	418	-	-	-	-	-	-	-	-	-
HB / HBA 50	-	338	350	362	387	421	-	-	-	-	-	-	-	-	-
HB / HBA 56	-	338	352	362	387	423	-	-	-	-	-	-	-	-	-
HB / HBA 63	-	-	352	386	411	442	463	-	-	-	-	-	-	-	-
HB / HBA 71	-	-	357	391	416	447	468	-	-	-	-	-	-	-	-
HB / HBA 80	-	-	-	427	427	463	469	525	563	-	-	-	-	-	-
HB / HBA 90	-	-	-	-	-	658	658	658	658	721	742	778	787	-	-
HB / HBA 100	-	-	-	-	-	-	-	653	653	716	738	776	792	-	-
HB / HBA 112	-	-	-	-	-	-	-	760	760	760	760	761	780	864	949
HB / HBA 125	-	-	-	-	-	-	-	759	759	759	759	760	779	863	948

MOTOR SIZE DEPENDING ON POWER (1 SPEED) / TAMAÑOS CONSTRUCTIVOS DE MOTORES SEGÚN POTENCIA (1 VELOCIDAD)

	Kw																		
	0,075	0,09	0,12	0,18	0,25	0,37	0,55	0,75	1,1	1,5	2,2	3	4	5,5	7,5	11	15	18,5	22
M2-T2 (3000rpm)	-	56	56	63	63	71	71	80	80	90S	90L	100L	112M	132S	132S	160M	160M	160L	180M
M4-T4 (1500rpm)	56	56	63	63	71	71	80	80	90S	90L	100L	100L	112M	132S	132M	160M	160L	180M	180L
M6-T6 (1000rpm)	-	63	-	71	71	80	80	90S	90L	100L	112M	132S	132M	132M	160M	160L	180L	200L	200L
M8-T8 (750rpm)	-	71	71	80	80	90S	90L	100L	100L	112M	132S	132M	160M	160M	160L	180L	200L	225S	225M

CONNECTION DIAGRAMS / esquema de conexiones

1 SINGLE PHASE MOTORS / motores monofásicos

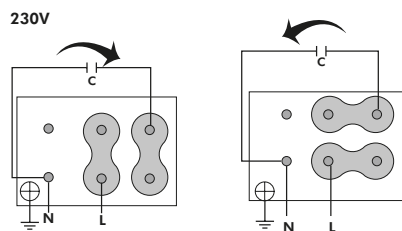



2 THREE PHASE MOTORS / motores trifásicos

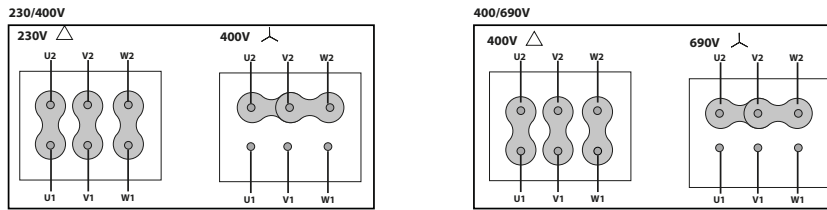

3 2 SPEEDS / 2 velocidades 400V DAHLANDER (Y,YY)

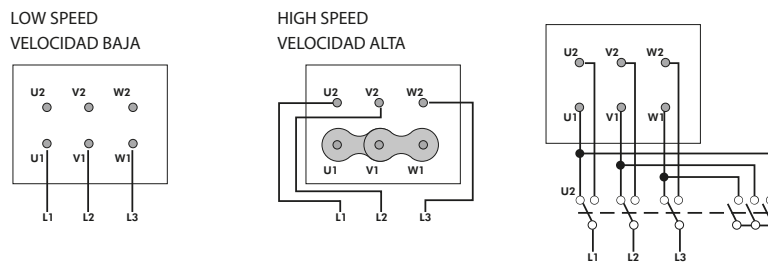

CONSULT / consultar - BOX HB / HBA

CHARACTERISTIC CURVES / curvas características

pg.55