



# HMX

ATEX long cased axial  
Helicoidal tubular ATEX



### MANUFACTURING FEATURES

- Reinforced fan casing manufactured in rolling steel sheet.
- Motor-impeller modular assembly for complete versatility.
- Protected against corrosion by powder coating of polyester resin.
- Cast aluminium impeller with variable pitch angle.
- ATEX standard asynchronous motor. ATEX certified: II2G Ex d, Ex e / II3G Ex nA. Standard voltages 230/400V 50Hz for three phase motors up to 4kW and 400/690V 50Hz for higher powers.

### APPLICATIONS

Designed for wall or duct installation, they are suitable for:

- Air renewal in buildings and industries.
- Smoke extraction (max. 45-50°C).
- Maximum continuous working temperature: 50°C.

### UNDER REQUEST

- B form impeller (air flow from impeller to motor).
- 100% reversible impeller. 5% additional cost.
- ATEX classification for other areas.

### CARACTERÍSTICAS CONSTRUCTIVAS

- Ventilador con envolvente tubular reforzada fabricada en chapa de acero laminado.
- Montaje modular del conjunto motor hélice que permite una total versatilidad en caso de cualquier cambio.
- Protegidos contra la corrosión mediante recubrimiento en polvo de resina de poliéster.
- Hélice en fundición de aluminio de ángulo variable en paro y en origen.
- Motor asíncrono normalizado ATEX, IP55. Certificación ATEX: II2G Ex d, Ex e / II3G Ex nA. Voltajes estándar 230/400V 50Hz para motores trifásicos hasta 4kW y 400/690V 50Hz para potencias superiores.

### APLICACIONES

Diseñados para montaje en pared o en conducto, son indicados para:

- Renovación de aire en todo tipo de edificios e industrias.
- Extracción de humos (máximo 45-50°C).
- Temperatura máxima de trabajo en continuo: 50°C.

### BAJO DEMANDA

- Hélice impelente (sentido de aire hélice-motor).
- Hélice reversible 100%.
- Clasificación ATEX para otras zonas.



### ATEX OPTIONS UNDER REQUEST | OPCIONES ATEX BAJO DEMANDA

Three-phase MOTOR explosion-proof under the ATEX 2014/34/EU Directive for working temperatures from -20°C to +40°C.  
MOTORES trifásicos antiexplosivos bajo Directiva ATEX 2014/34/UE para temperaturas de trabajo de -20°C a +40°C.

- ATEX Explosion-proof for GAS | ATEX Antideflagrantes para GAS
- ⓂII2G Ex d IIB T4 IP66
- ⓂII2G Ex d IIC T4 IP66 (OPTIONAL PTC PROBE | Sonda PTC OPCIONAL)
- ⓂII2G Ex d IIC T5 IP66
- ATEX Increased security for GAS | ATEX Seguridad aumentada para GAS:
- ⓂII2G Ex e T3 IP55
- ATEX Protection "n" for GAS | ATEX Protección "n" para GAS:
- ⓂII3G Ex nA IIC T4 Gc
- ATEX Protection "n" for GAS and NON-CONDUCTIVE DUST | ATEX Protección "n" para GAS y POLVO NO CONDUCTOR:
- ⓂII3GD Ex nA IIC T4 Gc Ex-rc IIIB T125° IP55 ZONA 22
- ATEX Explosion-proof for GAS and DUST | ATEX Antideflagrantes para GAS y POLVO:
- ⓂII2GD Ex d IIC T4 IP66
- ⓂII2GD Ex d IIC T5 IP66
- ATEX Increased security for DUST | ATEX Seguridad aumentada para POLVO:
- ⓂII3D Ex e Dc
- ATEX Protection by enclosure for DRIVER DUST | ATEX Protección por recinto para POLVO CONDUCTOR:
- ⓂII3D Ex-rc IIC T125° Dc IP55 ZONA 22

To carry out the selection of an ATEX fan, please use the curves that you will find in the Fanware by Casals selection software. The electrical data of these ATEX models can be modified.

Para llevar a cabo la selección de un ventilador ATEX, por favor use las curvas que encontrará en el programa de selección Fanware by Casals. Los datos eléctricos de estos Modelos ATEX pueden verse modificados.

## ACCESSORIES / accesorios



**INT**  
Interruptor de corte  
Safety switch



**INT ATEX**  
Interruptor para funcionar en entornos ATEX  
Switch for ATEX environments



**SFC**  
Variador de velocidad frecuencial  
Frequency speed controller



**RP**  
Rejilla de protección  
Protection guard



**JE 45**  
Junta elástica  
Flexible joint



**AC**  
Brida conexión  
Connection flange



**RP1**  
Rejilla de protección  
Inlet protection guard



**PO**  
Pie soporte para ventiladores tubulares  
Long cased axial fans mounting support



**BA-400**  
Brida antivibratoria 400°C/2h  
Flexible flange 400°C/2H



**SIL-C**  
Silenciador circular conducto  
Duct circular silencer



**BAD**  
Brida antivibratoria circular-circular  
Coupling flange



**PS**  
Pie soporte inclinable para HM  
Tilt mounting support for HM

## THREE PHASE RANGE / serie trifásica

### 2 POLE / 2 POLOS

Code	Model	R.P.M.	Rated I (A) 400V	Rated Power kW	Air flow m³/h	Sound dB (A)	Weight Kg	Connection diagram
2A0604018	HMX 40 T2 1,1kW	2830	2,6	1,1	7.850	64	22	1
2A0604519	HMX 45 T2 1,5kW	2850	3,95	1,5	9.750	69	23	1
2A0604527	HMX 45 T2 2,2kW	2840	5,4	2,2	12.160	69	24	1



## 4 POLE / 4 POLOS

Code	Model	R.P.M.	Rated I (A) 400V	Rated Power kW	Air flow m <sup>3</sup> /h	Sound dB (A)	Weight Kg	Connection diagram
2A0604041	HMX 40 T4 0,25kW	1400	0,84	0,25	4.660	48	25	1
2A0604542	HMX 45 T4 0,37kW	1410	1,2	0,37	6.600	49	21	1
2A0605043	HMX 50 T4 0,55kW	1430	1,75	0,55	8.750	59	26	1
2A0605643	HMX 56 T4 0,55kW	1430	1,75	0,55	8.680	67	29	1
2A0605644	HMX 56 T4 0,75kW	1410	2,1	0,75	10.810	56	30	1
2A0605645	HMX 56 T4 1,1kW	1420	3,3	1,1	12.520	57	34	1
2A0605646	HMX 56 T4 1,5kW	1415	3,8	1,5	14.600	60	36	1
2A0606344	HMX 63 T4 0,75kW	1410	2,1	0,75	12.020	67	39	1
2A0606345	HMX 63 T4 1,1kW	1420	3,3	1,1	14.740	56	43	1
2A0606346	HMX 63 T4 1,5kW	1415	3,8	1,5	16.610	62	45	1
2A0606354	HMX 63 T4 2,2kW	1440	5,8	2,2	18.630	58	56	1
2A0607145	HMX 71 T4 1,1kW	1420	3,3	1,1	16.800	70	47	1
2A0607146	HMX 71 T4 1,5kW	1415	3,8	1,5	19.960	62	50	1
2A0607154	HMX 71 T4 2,2kW	1440	5,8	2,2	23.200	69	65	1
2A0607156	HMX 71 T4 3kW	1420	6,8	3	25.160	62	67	1
2A0608056	HMX 80 T4 3kW	1420	6,8	3	31.090	72	73	1
2A0608059	HMX 80 T4 4kW	1450	9,1	4	34.000	67	78	1

## 6 POLE / 6 POLOS

Code	Model	R.P.M.	Rated I (A) 400V	Rated Power kW	Air flow m <sup>3</sup> /h	Sound dB (A)	Weight Kg	Connection diagram
2A0605069	HMX 50 T6 0,25kW	910	1	0,25	5.960	53	26	1
2A0605669	HMX 56 T6 0,25kW	910	1	0,25	7.700	58	26	1
2A0605670	HMX 56 T6 0,37kW	940	1,4	0,37	8.770	50	28	1
2A0606370	HMX 63 T6 0,37kW	940	1,4	0,37	10.760	55	37	1
2A0606371	HMX 63 T6 0,55kW	930	2	0,55	12.050	51	39	1
2A0607172	HMX 71 T6 0,75kW	930	2,2	0,75	16.250	53	50	1
2A0608072	HMX 80 T6 0,75kW	930	2,2	0,75	18.300	61	62	1
2A0608073	HMX 80 T6 1,1kW	910	3,2	1,1	20.550	63	64	1
2A0608074	HMX 80 T6 1,5kW	940	4	1,5	22.970	58	70	1
2A0608078	HMX 80 T6 2,2kW	930	5,2	2,2	25.190	57	75	1

## DIMENSIONS / dimensiones

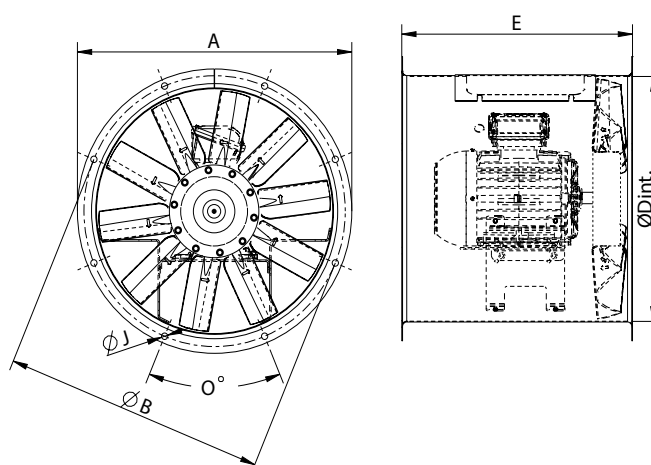

MODEL	Ø A	Ø B	Ø D	E	Ø I	O
HMX 40	472	450	403	440	10	8x45°
HMX 45	525	500	452	455	12	8x45°
HMX 50	600	560	504	440	12	12x30°
HMX 56	646	620	559	560	12	12x30°
HMX 63	725	690	633	550	12	12x30°
HMX 71	802	770	715	600	12	16x22,5°
HMX 80	892	860	801	600	12	16x22,5°



**CONNECTION DIAGRAMS / esquema de conexiones**

**1 THREE PHASE MOTORS 1 SPEED / motores trifásicos 1 velocidad**

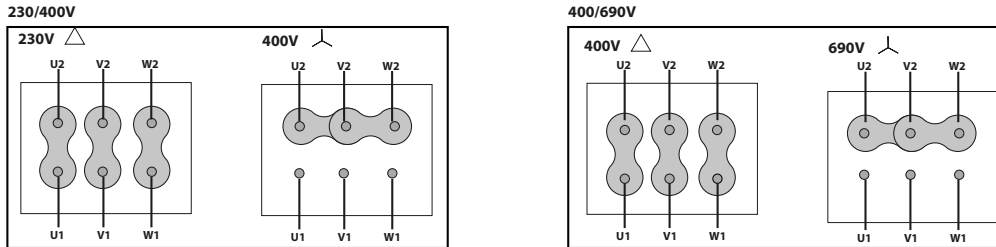

**CONSULT / consultar - HBX**

**CHARACTERISTIC CURVES / curvas características** pg.600